

INTERMEDIATE & TRUCK MOUNTED MACHINE TIPS (KC-700)				
TIP NUMBER	MINOR	MAJOR	ORIFICE SIZE (IN.)	MIL THICKNESS
XHD-437	4"	8"	.037"	15
XHD-439	4"	8"	.039	15
XHD-443	4"	8"	.043"	15
XHD-447	4"	8"	.047"	15
XHD-449	4"	8"	.049"	15
XHD-451	4"	8"	.051"	15
XHD-455	4"	8"	.055"	15
XHD-461	4"	8"	.061"	15
XHD-651	6"	12"	.051"	15
XHD-739	7"	14"	.039"	15
XHD-751	7"	14"	.051"	15
XHD-001	TIP GUARD			

TOLERANCES UNLESS OTHERWISE SPECIFIED:
 Angular $\pm 2^\circ$
 Fractional $\pm 1/16"$
 .X = ± 1
 .XX = ± 0.1
 .XXX = ± 0.005
 .XXXX = ± 0.0015

CONFIDENTIAL
 THIS DOCUMENT, INCLUDING ALL INFORMATION HEREIN, IS THE EXCLUSIVE AND CONFIDENTIAL PROPERTY OF ERNEST INDUSTRIES. THEREFORE THIS DOCUMENT IS NOT TO BE COPIED, REPRODUCED, OR DELIVERED TO OTHERS WITHOUT THE EXPRESS WRITTEN PERMISSION OF ERNEST INDUSTRIES.

Kelly-Creswell
 1221 Groop Rd.
 Springfield, OH 45504
 937-325-3978
KC Since 1937

DRAWN BY
 CDW
 APPROVED BY

DATE
 11-09-10
 DATE APPROVED

TITLE:
2000-AL
 DESCRIPTION:
GENERAL DETAILS (TANKS)

DWG NO./PART NO.
SA-2000AL TOP LEVEL

SCALE: NA SIZE: A PAGE #: 1-7 REV: A

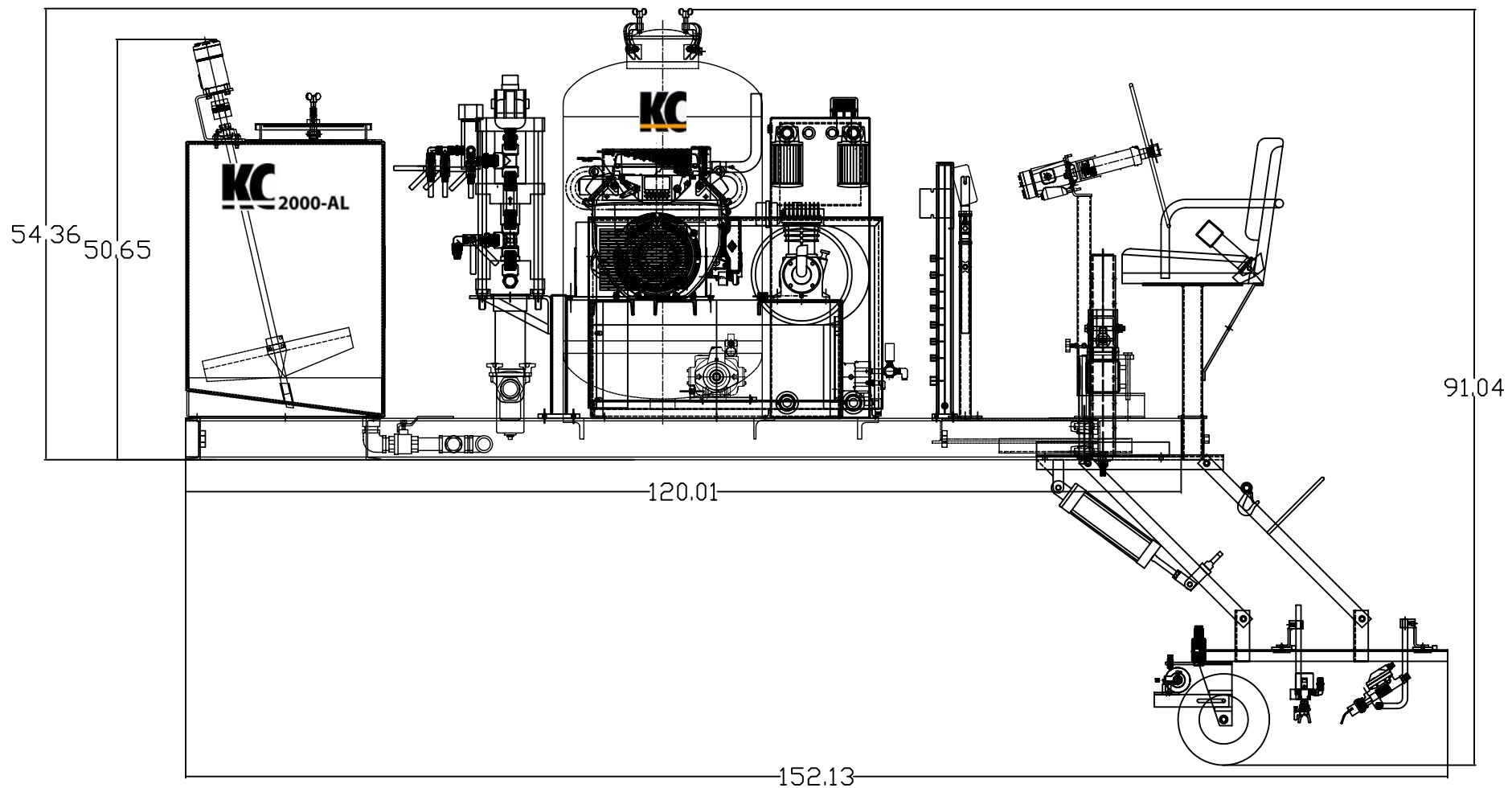

TOLERANCES UNLESS OTHERWISE SPECIFIED:
 Angular $\pm 2^\circ$
 Fractional $\pm 1/16"$
 .X = ± 1
 .XX = ± 0.1
 .XXX = ± 0.005
 .XXXX = ± 0.0015

CONFIDENTIAL
 THIS DOCUMENT, INCLUDING ALL INFORMATION HEREIN, IS THE EXCLUSIVE AND CONFIDENTIAL PROPERTY OF ERNEST INDUSTRIES. THEREFORE THIS DOCUMENT IS NOT TO BE COPIED, REPRODUCED, OR DELIVERED TO OTHERS WITHOUT THE EXPRESS WRITTEN PERMISSION OF ERNEST INDUSTRIES.

Kelly-Creswell
 1221 Groop Rd.
 Springfield, OH 45504
 937-325-3978
KC Since 1937

DRAWN BY CDW	DATE 11-9-10
APPROVED BY	DATE APPROVED

TITLE: 2000-AL			
DESCRIPTION: BASIC DIMENSIONS (TANKS)			
DWG NO./PART NO. SA-2000AL TOP LEVEL			
SCALE: N/A	SIZE: A	PAGE #: 2-7	REV: A

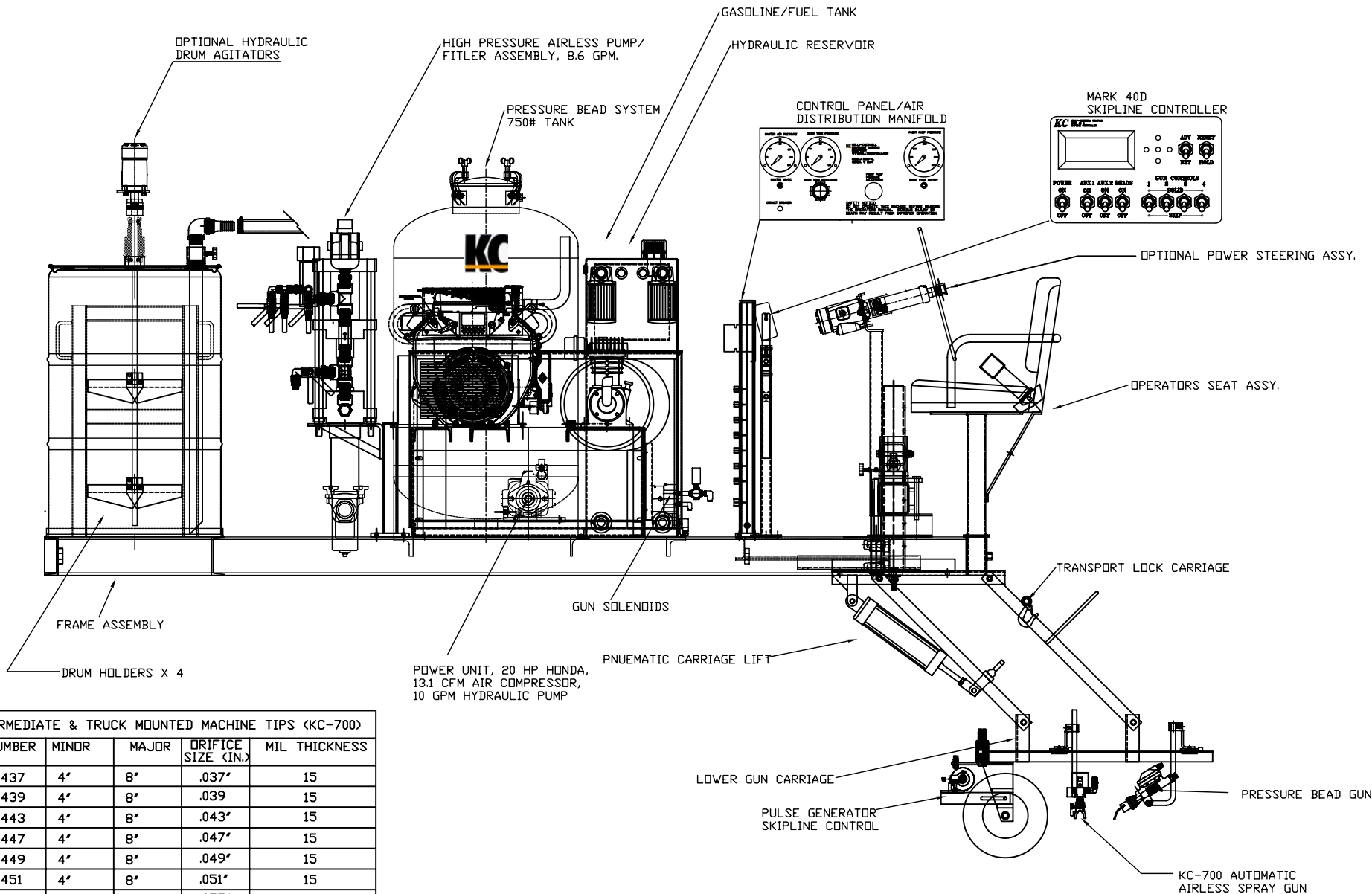

INTERMEDIATE & TRUCK MOUNTED MACHINE TIPS (KC-700)

TIP NUMBER	MINOR	MAJOR	ORIFICE SIZE (IN.)	MIL THICKNESS
XHD-437	4"	8"	.037"	15
XHD-439	4"	8"	.039	15
XHD-443	4"	8"	.043"	15
XHD-447	4"	8"	.047"	15
XHD-449	4"	8"	.049"	15
XHD-451	4"	8"	.051"	15
XHD-455	4"	8"	.055"	15
XHD-461	4"	8"	.061"	15
XHD-651	6"	12"	.051"	15
XHD-739	7"	14"	.039"	15
XHD-751	7"	14"	.051"	15
XHD-001	TIP GUARD			

TOLERANCES UNLESS OTHERWISE SPECIFIED:
 Angular ±2°
 Fractional ±1/16"
 .X= ±1
 .XX=±.01
 .XXX=±.005
 .XXXX=±.0015

CONFIDENTIAL
 THIS DOCUMENT, INCLUDING ALL INFORMATION HEREIN, IS THE EXCLUSIVE AND CONFIDENTIAL PROPERTY OF ERNEST INDUSTRIES. THEREFORE THIS DOCUMENT IS NOT TO BE COPIED, REPRODUCED, OR DELIVERED TO OTHERS WITHOUT THE EXPRESS WRITTEN PERMISSION OF ERNEST INDUSTRIES.

Kelly-Creswell
 1221 Groop Rd.
 Springfield, OH 45504
 937-325-3978

KC Since 1937

DRAWN BY: CDW
 DATE: 11-9-10
 APPROVED BY: [Signature]
 DATE APPROVED: [Signature]

TITLE:
2000-AL

DESCRIPTION:
GENERAL DETAILS (DRUMS)

DWG NO./PART NO.
SA-2000AL TOP LEVEL

SCALE: N/A
 SIZE: A
 PAGE #: 3-7
 REV: A

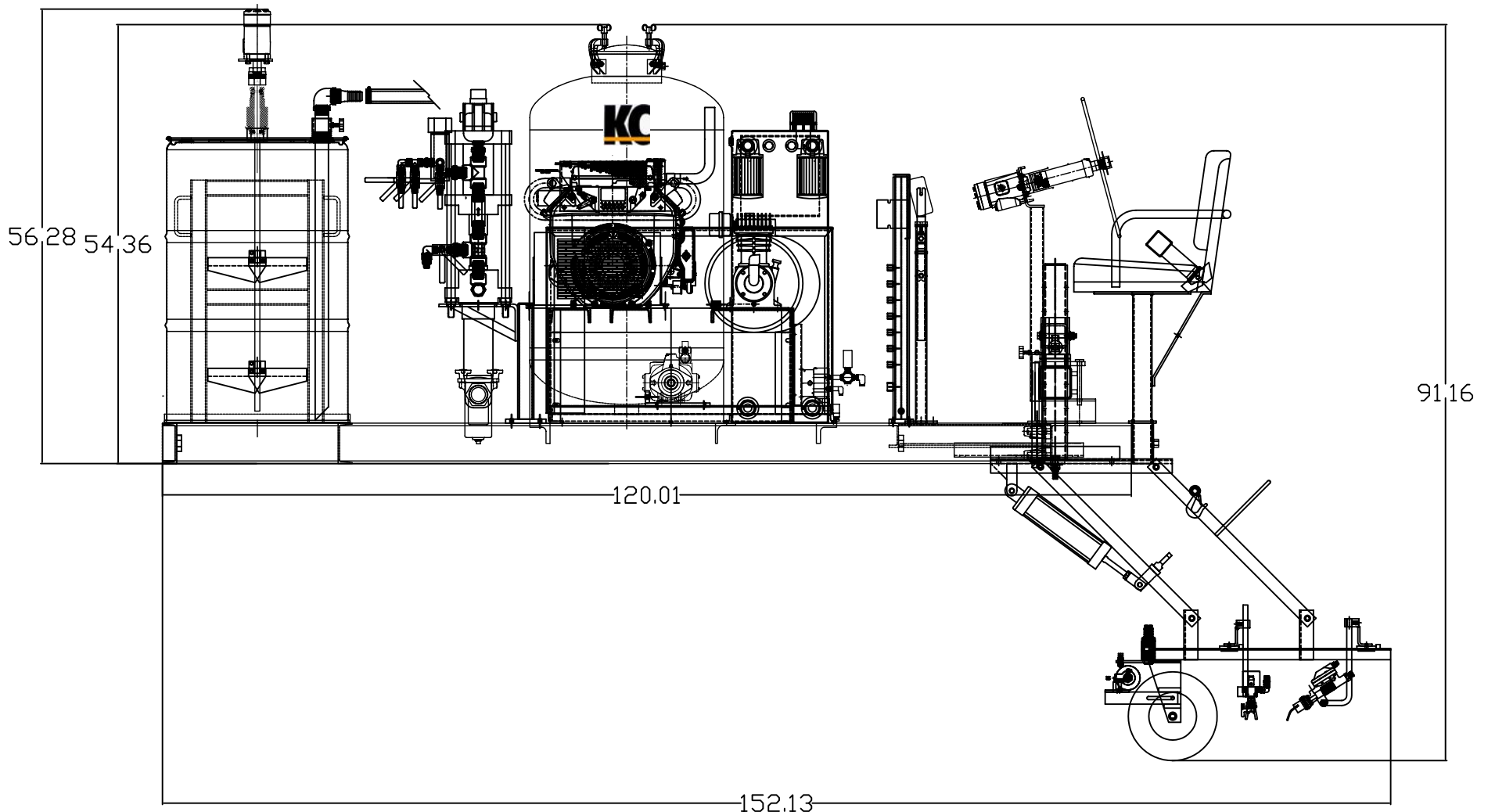

TOLERANCES UNLESS OTHERWISE SPECIFIED:
 Angular $\pm 2^\circ$
 Fractional $\pm 1/16"$
 .X = ± 1
 .XX = ± 0.1
 .XXX = ± 0.005
 .XXXX = ± 0.0015

CONFIDENTIAL
 THIS DOCUMENT, INCLUDING ALL INFORMATION HEREIN, IS THE EXCLUSIVE AND CONFIDENTIAL PROPERTY OF ERNEST INDUSTRIES. THEREFORE THIS DOCUMENT IS NOT TO BE COPIED, REPRODUCED, OR DELIVERED TO OTHERS WITHOUT THE EXPRESS WRITTEN PERMISSION OF ERNEST INDUSTRIES.

Kelly-Creswell
 1221 Groop Rd.
 Springfield, OH 45504
 937-325-3978
KC Since 1937

DRAWN BY
 CDW
 APPROVED BY
 DATE
 11-9-10
 DATE APPROVED

TITLE: 2000-AL			
DESCRIPTION: BASIC DIMENSIONS (DRUMS)			
DWG NO./PART NO. SA-2000AL TOP LEVEL			
SCALE: N/A	SIZE: A	PAGE #: 4-7	REV: A

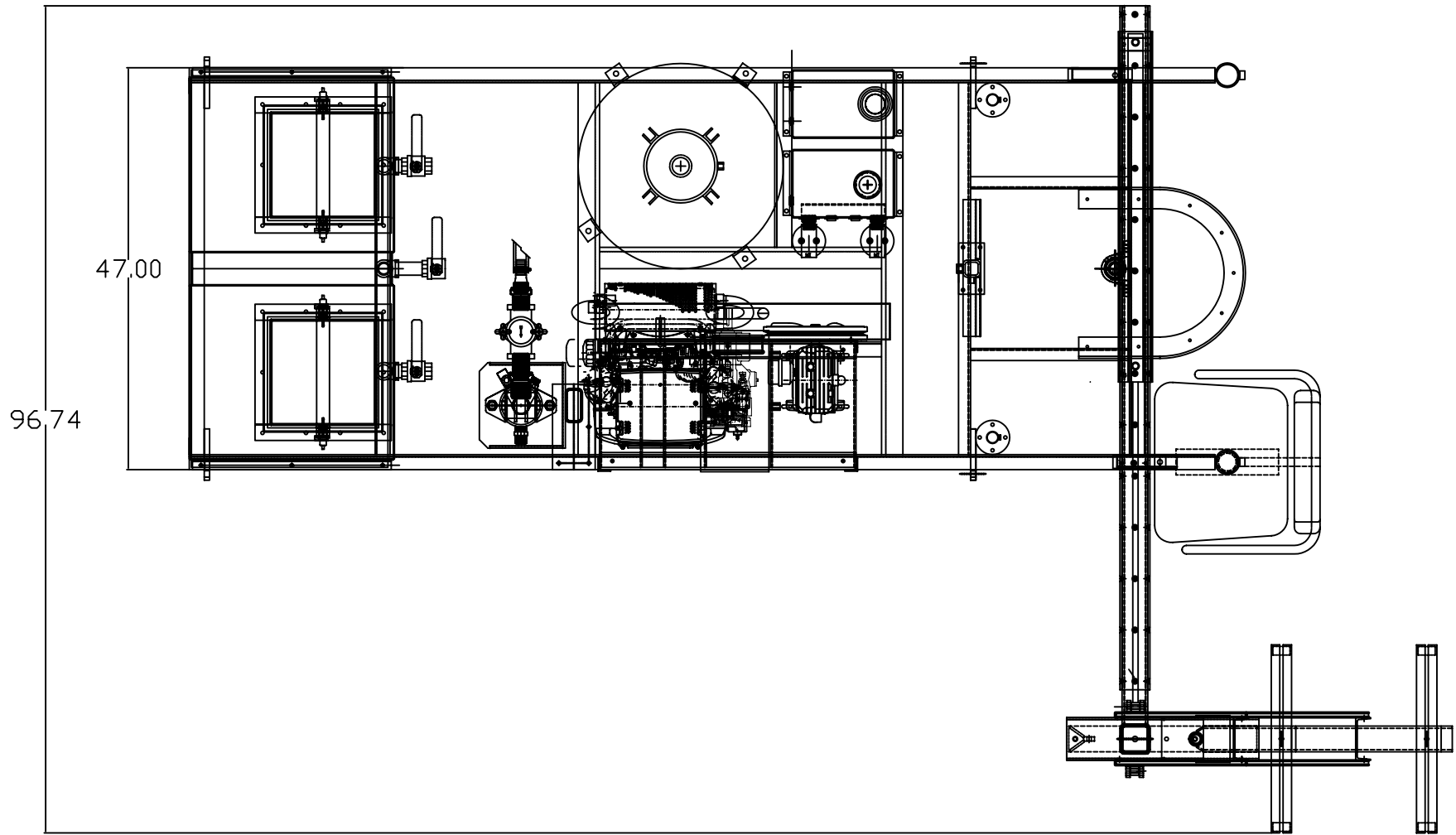

TOLERANCES UNLESS OTHERWISE SPECIFIED:
 Angular $\pm 2^\circ$
 Fractional $\pm 1/16"$
 .X = ± 1
 .XX = ± 0.1
 .XXX = ± 0.005
 .XXXX = ± 0.0015

CONFIDENTIAL
 THIS DOCUMENT, INCLUDING ALL INFORMATION HEREIN, IS THE EXCLUSIVE AND CONFIDENTIAL PROPERTY OF ERNEST INDUSTRIES. THEREFORE THIS DOCUMENT IS NOT TO BE COPIED, REPRODUCED, OR DELIVERED TO OTHERS WITHOUT THE EXPRESS WRITTEN PERMISSION OF ERNEST INDUSTRIES.

Kelly-Creswell
 1221 Groop Rd.
 Springfield, OH 45504
 937-325-3978
KC Since 1937

DRAWN BY
 CDW
 APPROVED BY

DATE
 11-9-10
 DATE APPROVED

TITLE: 2000-AL			
DESCRIPTION: BASIC DIMENSIONS (TANKS)			
DWG NO./PART NO. SA-2000AL TOP LEVEL		PAGE #: 5-7	
SCALE: N/A	SIZE: A	REV: A	

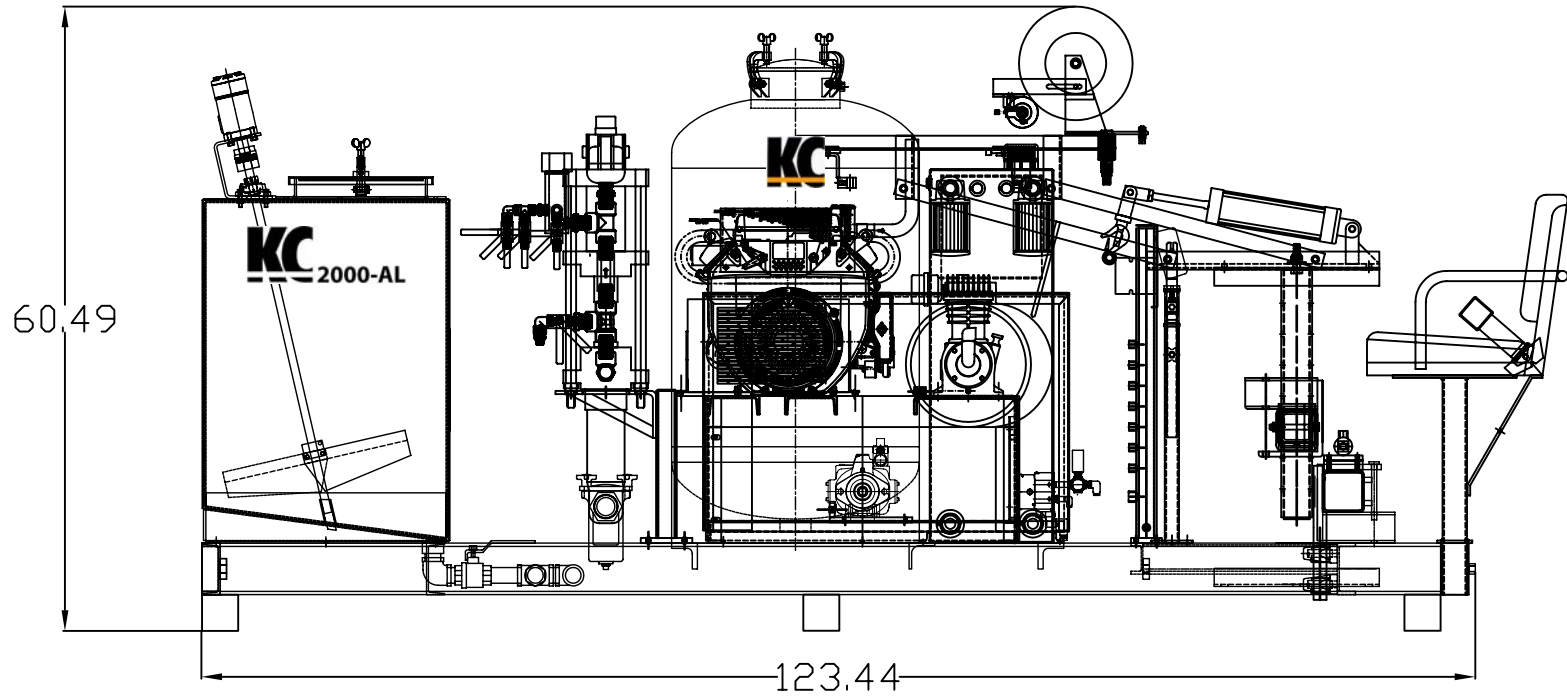

LENGTH (INCHES)	124"
WIDTH (INCHES)	90"
HEIGHT (INCHES)	61"
EST. SHIPPING WEIGHT	
TANKS	2500 LBS
DRUMS	1800 LBS

NOTE:
LTL SHIPMENT WITHIN UNITED STATES
SHIPPED ON AN OPEN FLAT DECK
TRAILER.

TOLERANCES UNLESS OTHERWISE SPECIFIED: Angular $\pm 2^\circ$ Fractional $\pm 1/16"$.X = ± 1 .XX = ± 0.1 .XXX = ± 0.005 .XXXX = ± 0.0015		CONFIDENTIAL THIS DOCUMENT, INCLUDING ALL INFORMATION HEREIN, IS THE EXCLUSIVE AND CONFIDENTIAL PROPERTY OF ERNEST INDUSTRIES. THEREFORE THIS DOCUMENT IS NOT TO BE COPIED, REPRODUCED, OR DELIVERED TO OTHERS WITHOUT THE EXPRESS WRITTEN PERMISSION OF ERNEST INDUSTRIES.		Kelly-Creswell 1221 Groop Rd. Springfield, OH 45504 937-325-3978  Since 1937		TITLE: 2000-AL DESCRIPTION: SHIPPING DIMENSIONS (TANKS)	
DRAWN BY CDW		DATE 11-9-10		DWG NO./PART NO. SA-2000AL TOP LEVEL		SCALE: N/A	
APPROVED BY		DATE APPROVED		SIZE: A		PAGE #: 6-7	
				REV: A			

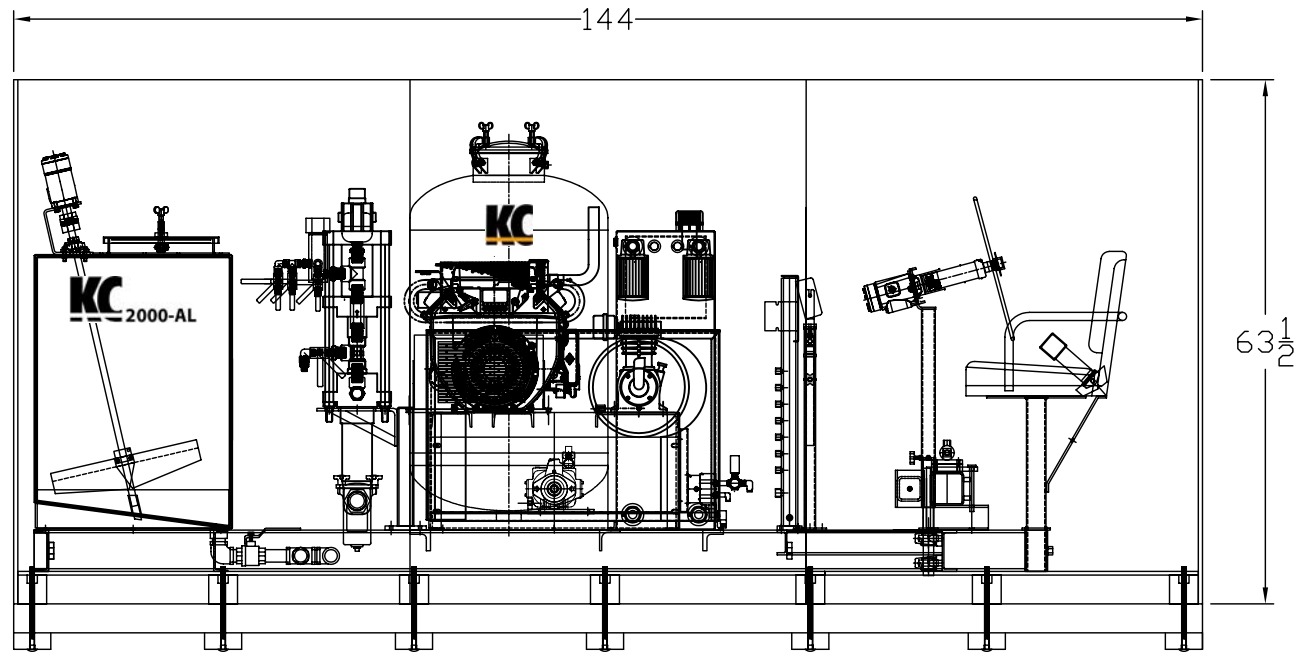
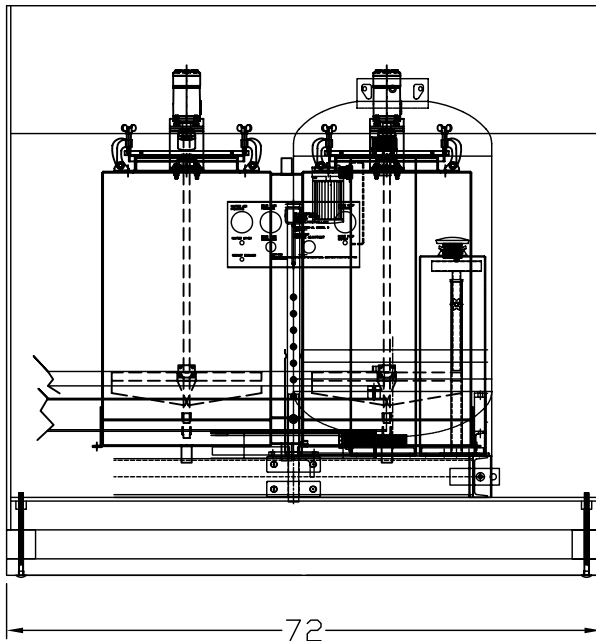

NOTE:
 *FULLY ENCLOSED EXPORT CRATE
 OR OPEN FRAME SKID

*CARRIAGE ASSEMBLY REMOVED,
 CUSTOM FITTED AND BRACED TO
 SPACE AVAILABLE IN CRATE

LENGTH (INCHES)	144'
WIDTH (INCHES)	72'
HEIGHT (INCHES)	63.5'
EST. SHIPPING WEIGHT	
TANKS	3000 LBS
DRUMS	2300 LBS
APPROX. CUBIC FEET	381'

TOLERANCES UNLESS OTHERWISE SPECIFIED: Angular ±2° Fractional ±1/16" .X= ±.1 .XX=±.01 .XXX=±.005 .XXXX=±.0015		CONFIDENTIAL THIS DOCUMENT, INCLUDING ALL INFORMATION HEREIN, IS THE EXCLUSIVE AND CONFIDENTIAL PROPERTY OF ERNEST INDUSTRIES. THEREFORE THIS DOCUMENT IS NOT TO BE COPIED, REPRODUCED, OR DELIVERED TO OTHERS WITHOUT THE EXPRESS WRITTEN PERMISSION OF ERNEST INDUSTRIES.		Kelly-Creswell 1221 Groop Rd. Springfield, OH 45504 937-325-3978  Since 1937		TITLE: 2000 SERIES EXPORT CRATE	
				DESCRIPTION: EXPORT CRATE, 2000 SERIES			
				DWG NO./PART NO. AC-2099 EXPORT CRATING			
DRAWN BY CDW	DATE 11-9-10	APPROVED BY	DATE APPROVED	SCALE: N/A	SIZE: A	PAGE #: 7-7	REV: A